



# SC7020x User Manual

**Low power single touch single output IC**

**Rev. 1.2.0**

Please note the following CMS IP policy

\* China Micro Semicon Co., Ltd. (hereinafter referred to as the Company) has applied for patents and holds absolute legal rights and interests. The patent rights associated with the Company's MCUs or other products have not been authorized for use, and any company, organization, or individual who infringes the Company's patent rights through improper means will be subject to all possible legal actions taken by the Company to curb the infringement and to recover any damages suffered by the Company as a result of the infringement or any illegal benefits obtained by the infringer.

\* The name and logo of Cmsemicon are registered trademarks of the Company.

\* The Company reserves the right to further explain the reliability, functionality and design improvements of the products in the data sheet. However, the Company is not responsible for the use of the Specification Contents. The applications mentioned herein are for illustrative purposes only and the Company does not warrant and does not represent that these applications can be applied without further modification, nor does it recommend that its products be used in places that may cause harm to persons due to malfunction or other reasons. The Company's products are not authorized for use as critical components in lifesaving, life-sustaining devices or systems. The Company reserves the right to modify the products without prior notice. For the latest information, please visit the official website at [www.mcu.com.cn](http://www.mcu.com.cn).

---

## Table of Contents

<b>1. PRODUCT DESCRIPTION</b> .....	<b>3</b>
<b>2. CHARACTERISTIC</b> .....	<b>3</b>
<b>3. PRODUCT SPECIFICATION</b> .....	<b>3</b>
<b>4. SYSTEM STRUCTURE DIAGRAM</b> .....	<b>4</b>
<b>5. PACKAGING AND PIN DESCRIPTION</b> .....	<b>5</b>
5.1 SC70201, SC70202 Pin Diagram .....	5
5.2 SC70205 Pin Diagram .....	6
<b>6. FUNCTION DESCRIPTION</b> .....	<b>7</b>
6.1 Output Mode and Pad Option .....	7
6.2 Maximum output time of key .....	7
6.3 Low Power Mode .....	7
6.4 Sensitivity adjustment .....	8
<b>7. APPLICATION CIRCUIT</b> .....	<b>9</b>
<b>8. ELECTRICAL CHARACTERISTICS</b> .....	<b>10</b>
8.1 Limit Parameters of Electrical Characteristics .....	10
8.2 DC Characteristics .....	10
<b>9. PACKAGING</b> .....	<b>11</b>
9.1 SOT23-6 .....	11
<b>10. VERSION REVISION</b> .....	<b>12</b>

## 1. Product Description

SC7020x is a touch pad detector IC which offers 1 touch key. The device built-in voltage regulator circuit to provide a stable voltage for the touch sensing circuit, while the internal integration of efficient and perfect touch detection algorithm, so that the chip has a stable touch detection effect. The touching detection IC is designed for replacing traditional direct button key with wide operating voltage and low power consumption, which can widely meet the needs of different consumer applications

## 2. Characteristic

- ◆ Working voltage: 2.4~5.5V
- ◆ Working temperature: -40~85°C
- ◆ Excellent anti-interference performance: built-in voltage regulator circuit, power-on reset, low-voltage reset function and environment adaptive algorithm and other measures
- ◆ Low power standby current: Typical value 0.8uA@VDD=3V/no load
- ◆ The key response time max about 220mS at low power mode @VDD=3V
- ◆ Sensitivity can adjust by the capacitance (3~50pF) outside
- ◆ Output type selection (TOG) : synchronous output or toggle output
- ◆ Output optional CMOS output (QC) or Open drain output (QD)
- ◆ Maximum output time of key: 8 s/16 s/64s~ infinity (±30%)
- ◆ After power-on have about 0.4s stable-time, during the time do not touch the key pad, and the function is disabled
- ◆ the function is disabled HBM ESD: more than 5KV
- ◆ Packaging: SOT23-6

## 3. Product Specification

Product	Maximum output time				Output type	
	infinity	16s	8s	64s	Push-pull output	Open drain output
SC70201	■				■	
SC70202		■			■	
SC70205	■					■

## 4. System Structure Diagram

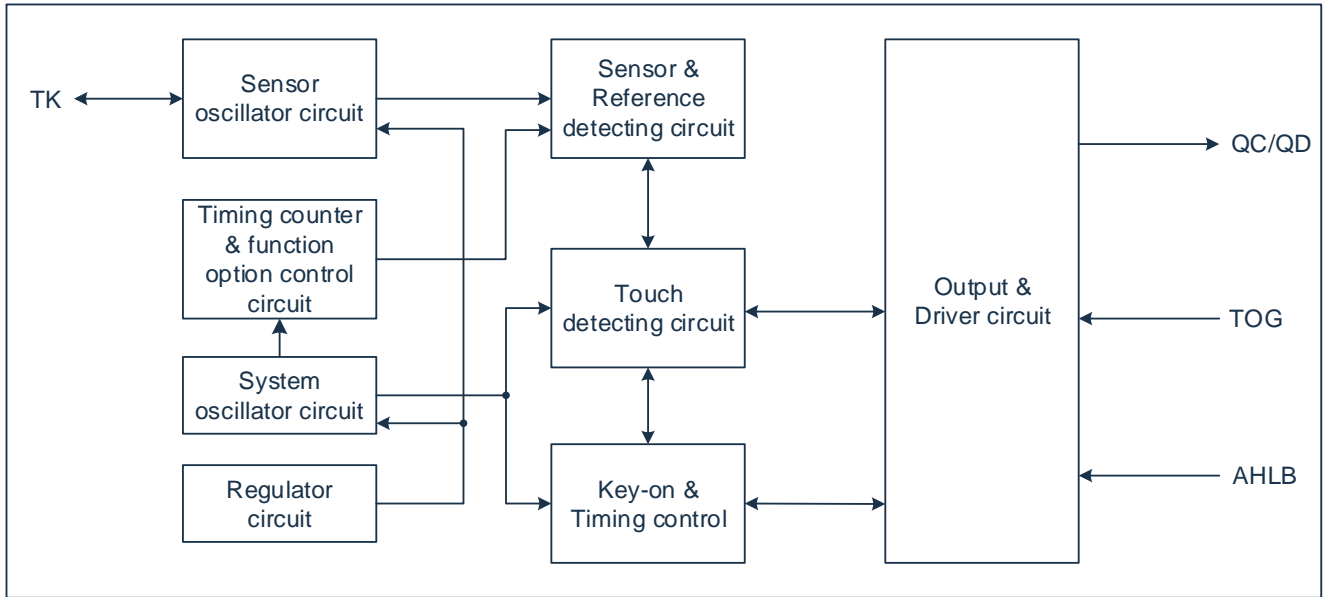

## 5. Packaging and Pin Description

### 5.1 SC70201, SC70202 Pin Diagram



#### Pin Description:

Pad NO	Pin name	I/O type	description
1	QC	O	CMOS output pin
2	GND	P	Negative power supply, ground
3	TK	I	Touch key sensor input pin
4	AHLB	I-PL	Output QC active high or low selection 0(Default):Active high; 1:Active low
5	VDD	P	Positive power supply
6	TOG	I-PL	Output type selection 0 (Default): synchronous output; 1: toggle output

#### Pin Type:

- ◆ I CMOS input
- ◆ O CMOS output
- ◆ I/O CMOS I/O
- ◆ P Power / Ground
- ◆ I-PH CMOS input and pull-high resister
- ◆ I-PL CMOS input and pull-low resister

## 5.2 SC70205 Pin Diagram



### Pin Description:

Pad NO	Pin name	I/O type	description
1	QD	OD	Open drain output pin
2	GND	P	Negative power supply, ground
3	TK	I	Touch key sensor input pin
4	AHLB	I-PL	Output QC active high or low selection 0(Default):Active high; 1:Active low
5	VDD	P	Positive power supply
6	TOG	I-PL	Output type selection 0 (Default): synchronous output; 1: toggle output

### Pin Type:

- ◆ I CMOS input
- ◆ OD Open drain output
- ◆ I/O CMOS I/O
- ◆ P Power / Ground
- ◆ I-PH CMOS input and pull-high resister
- ◆ I-PL CMOS input and pull-low resister

## 6. Function Description

### 6.1 Output Mode and Pad Option

The AHLB and TOG pads are latches: The default status is low. If the pads are connected to VDD before power-on, the status changes to high after power-on, and no current leakage occurs.

TOG pad: Synchronous output or toggle output selection.

AHLB pad: Output CMOS active high or active low selection.

Pad QC (CMOS output) option features:

TOG	AHLB	Pad QC/QD features
0	0	Synchronous output, CMOS active high
0	1	Synchronous output, CMOS active low
1	0	Toggle output, power on state = 0
1	1	Toggle output, power on state = 1

### 6.2 Maximum output time of key

Objects covering the touchpad or sudden changes in the environment may cause touch detection to remain active. The system will return to the initial state of power-on and the output will become invalid, when the IC's internal touch algorithm detects that the output valid duration reaches the set value of 8s/16s/64s ( $\pm 30\%$ ).

### 6.3 Low Power Mode

SC7020x in the Low Power mode it will be saving power. In this mode when detecting key touch, it will switch to Fast mode. Until the key touch is released and will keep a time about 10 s. Then it returns to Low Power mode.

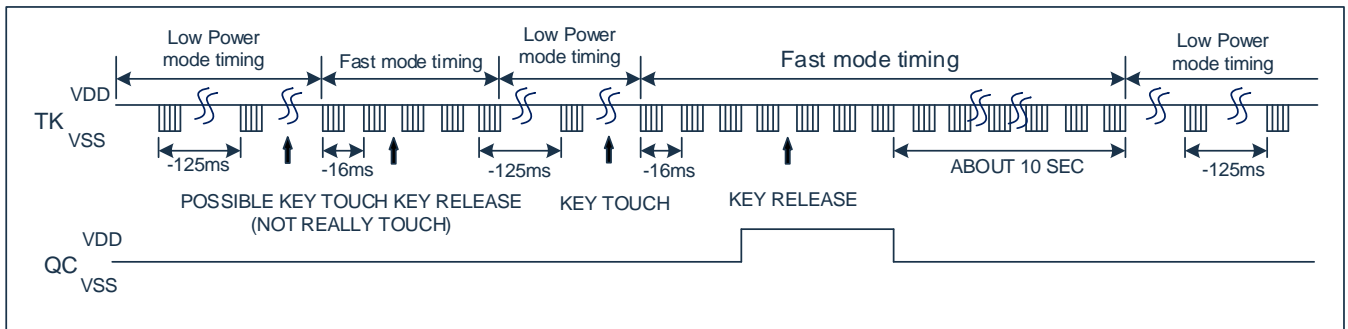

---

## 6.4 Sensitivity adjustment

The equivalent capacitance on the IC touch pad will affect the sensitivity. So the sensitivity adjustment must according to the practical application on PCB. The SC7020x offers some methods for adjusting the sensitivity outside.

- 1) By the touchpad size: Under other conditions are fixed. Using a larger touchpad size can increase sensitivity. Otherwise it can decrease sensitivity. But the touchpad size must use in the effective scope.
- 2) By the panel thickness: Under other conditions are fixed. Using a thinner panel can increase sensitivity. Otherwise it can decrease sensitivity.
- 3) By the value of Cs: Under other conditions are fixed. When the touchpad is not use the Cs to GND, the sensitivity is most sensitive. When adding the value of Cs will reduce sensitivity in the useful range ( $3 \leq C_s \leq 50\text{pF}$ ) .



## 7. Application circuit

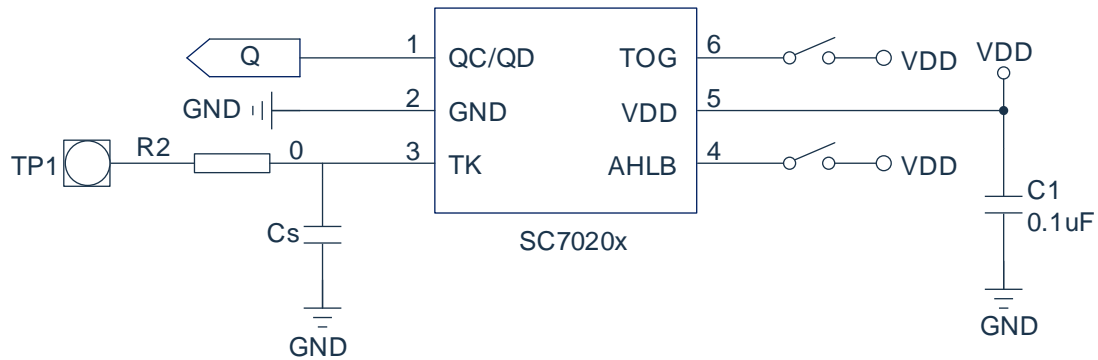

Figure 7-1: Schematic diagram of the circuit

### Note:

- 1) On PCB, the length of lines from touch pad to IC pin shorter is better. And the lines do not parallel and cross with other lines.
- 2) The power supply must be stable. If the supply voltage drift or shift quickly, maybe causing sensitivity anomalies or false detections.
- 3) The material of panel covering on the PCB can not include the metal or the electric element. The paints on the surfaces are the same.
- 4) The C1 capacitor (104 or larger) must be used between VDD and GND; and should be routed with very short tracks to the device's VDD and GND pins.
- 5) The capacitance Cs can be used to adjust the sensitivity. The value of Cs uses smaller, then the sensitivity will be better. The sensitivity adjustment must according to the practical application on PCB. The range of Cs value are 3~50pF.
- 6) The sensitivity adjustment capacitors (Cs) must use smaller temperature coefficient and more stable capacitors. Such are X7R, NPO for example. So for touch application, recommend to use NPO capacitor, for reducing that the temperature varies to affect sensitivity.

## 8. Electrical Characteristics

### 8.1 Limit Parameters of Electrical Characteristics

Limit Parameters

Parameter	Symbol	Conditions	Rating	Unit
Supply Voltage	VDD	-	-0 to +5.5	V
Input Voltage	VI	All I/O port	-0.3 to VDD+0.3	V
Working temperature	TA	-	-40~ +85	°C
Storage Temperature	TSTG	-	-50~ +125	°C
Human Body Mode	ESD		5	KV

### 8.2 DC Characteristics

(VDD=2.0V~5.5, TA= 25°C, unless otherwise indicated)

Parameter	Symbol	Conditions	Min	Typ	Max	Unit
Working voltage	VDD		2.4	3	5.5	V
Internal Regulator Output	VREG		2.0	2.2	2.4	V
High level input voltage	VIH		0.75		1.0	VDD
Low level input voltage	VIL		0		0.25	VDD
Output Port Source Current	IOH	VDD=3V, VOH=2.1V		-9		mA
Output Port Sink Current	IOL	VDD=3V, VOL=0.9V		25		mA
Input Pin Pull-low Resistor	RPL	VDD=3V (TOG, AHLB)		55K		ohm
Output Response Time	TR	VDD=3V, At fast mode			20	ms
		VDD=3V, At low power mode			200	
Working current	ISB	VDD=3V, At low power mode (no load)		0.8	1.5	μA
		VDD=3V, At fast mode(no load)		1.6	3	

## 9. Packaging

### 9.1 SOT23-6

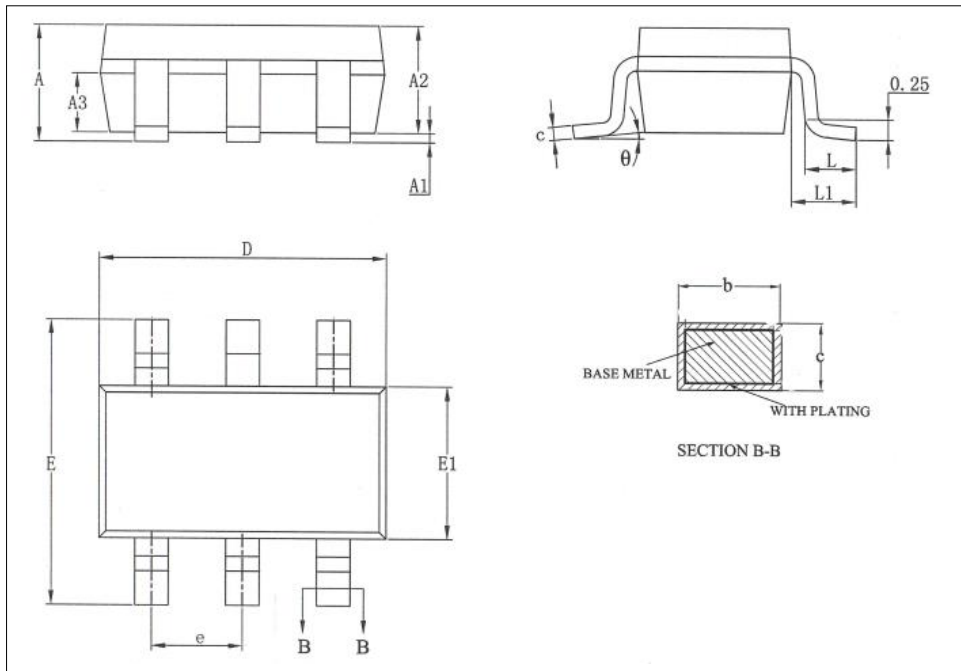

Symbol	Millimeter		
	Min	Nom	Max
A	1	-	1.35
A1	0.01	-	0.15
A2	0.90	-	1.20
A3	0.55	-	0.80
b	0.30	-	0.50
c	0.12	-	0.21
D	2.77	-	3.07
E	2.65	2.80	3.00
E1	1.40	1.60	1.80
e	0.95BSC		
L	0.30	-	0.60
L1	0.52	-	0.75
$\theta$	0	-	8°

Caution: Package dimensions do not include mold flash or gate burrs.

## 10. Version Revision

Version number	Date	Revised content
V1.0	May 2020	Original version
V1.1	Dec 2021	Delete some chip products
V1.2.0	Oct 2024	1) Revised the cover page 2) Modified SOT23-6 package dimensions